

Description:

The purpose of the section is to highlight the current applicable UMCP Design Standards for the design, selection and installation of common site features utilized on the campus.

Related Sections:

- TBD

Effective Date:

November 20, 2013

Applicable Standards:

- TBD

General Requirements:

Site standards have been established for the following items:

- **Concrete Steps**
- **Curbs**
 - Bituminous Concrete Curb
 - 6" and 8" Concrete Curb and Gutter
 - 8" Mountable Curb
 - 4" Concrete Landscape Curb
- **Handrails**
- **Paving**
 - Concrete Pavers
 - Concrete Walks
 - Bituminous Asphalt Paving
 - Brick on Concrete
- **Planting Details**
 - Trees
 - Shrubs
- **Ramps for Persons with Disabilities (PWD)**
 - PWD Ramp, Plan View
 - PWD Ramp, Section
- **Tree Grates**

Specific Requirements:

1. Concrete Steps

- Material: As indicted on detail
- Manufacturer: As indicted on detail
- Model: As indicted on detail
- Description: As indicted on detail
- Performance: As indicted on detail
- Related Details: Refer to detail numbered 1.

2. Curbs

- Bituminous Concrete Curb
- 6" and 8" Concrete Curb and Gutter
- 8" Mountable Curb
- 4" Concrete Landscape Curb
 - Material: As indicted on details
 - Manufacturer: As indicted on details
 - Model: As indicted on details
 - Description: As indicted on details
 - Performance: As indicted on details
 - Related Details: Refer to details numbered 2a, 2b, and 2c.

3. Handrails

- Material: Molded steel with flat black paint finish.
- Manufacturer: ACME Iron Works, Inc. Tuxedo, Md.
- Model: Style #104 or similar style
- Description: Molded steel with red enamel primer and black flat paint finish. Molded top bar, 1/2" square pickets spaced 4" O.C. and a lamb's tongue.
- Performance: Placed on steps of more than three treads and as required by ADA Standards.
- Related Details: Refer to detail number 3.

4. Paving

- Interlocking Concrete Pavers
- Concrete Walk
- Bituminous Asphalt Paving
- Brick on Concrete
 - Material: As indicted on details
 - Manufacturer: As indicted on details
 - Model: As indicted on details
 - Description: As indicted on details
 - Performance: As indicted on details
 - Related Details: Refer to details numbered 4a, 4b, 4c and 4d.

5. Planting Details

- Tree
- Shrub
 - Material: As indicted on details
 - Manufacturer: As indicted on details
 - Model: As indicted on details
 - Description: As indicted on details
 - Performance: As indicted on details
 - Related Details: Refer to details numbered 5a, and 5b.

6. Ramps for Persons with Disabilities (PWD)

- PWD Ramp, Plan View
- PWD Ramp, Section
 - Material: As indicted on details
 - Manufacturer: As indicted on details
 - Model: As indicted on details
 - Description: As per ADA Guidelines
 - Performance: As indicted on details
 - Related Details: Refer to details numbered 6a, and 6b.

7. Security Gates

- Material: As indicted on detail
- Manufacturer: As indicted on detail
- Model: As indicted on detail
- Description: As indicted on detail
- Performance: As indicted on detail
- Related Details: Refer to detail numbered 7.

8. Tree Grates

- Material: Cast Iron
- Manufacturer: Neehan Foundry Company or Equal.
- Model: As specified
- Description: 90 degree round with cast iron angle frame.
- Performance: Install flush with adjacent surfaces.
- Related Details: Refer to detail numbered 8a and 8b.

Site Standard Detail #1

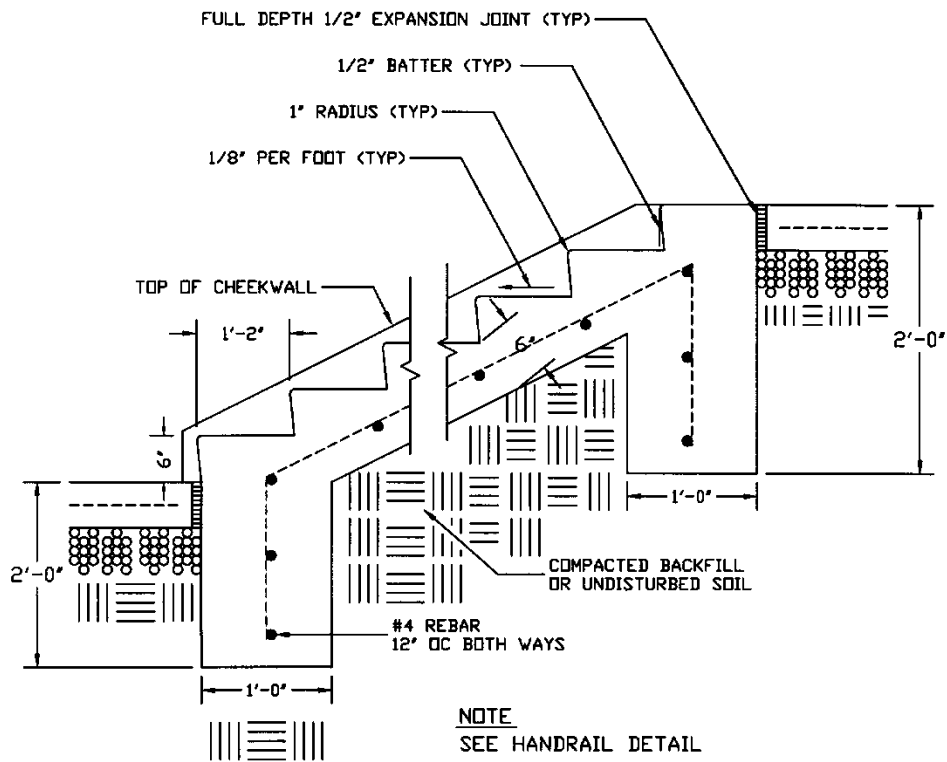

Site Standard Detail #2a

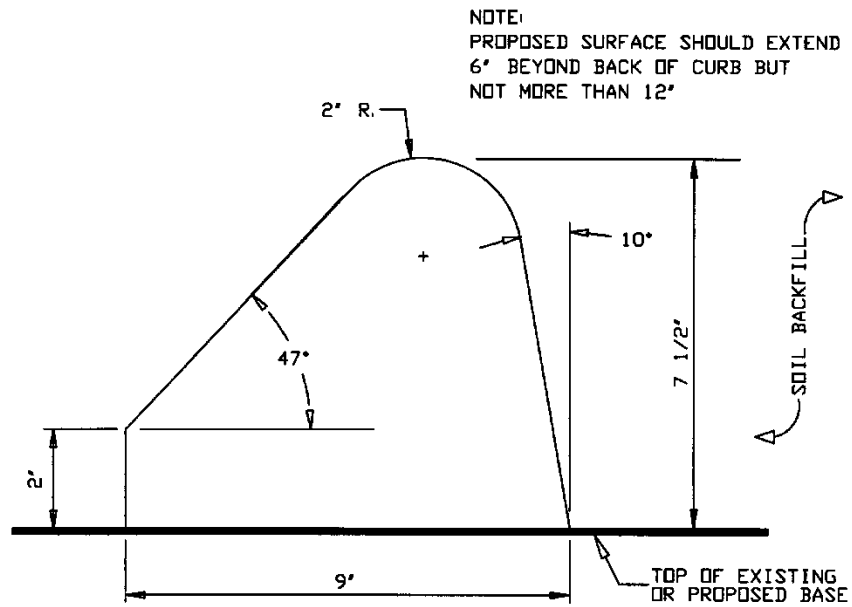

BITUMINOUS CONCRETE CURB

NTS

Site Standard Detail #2b

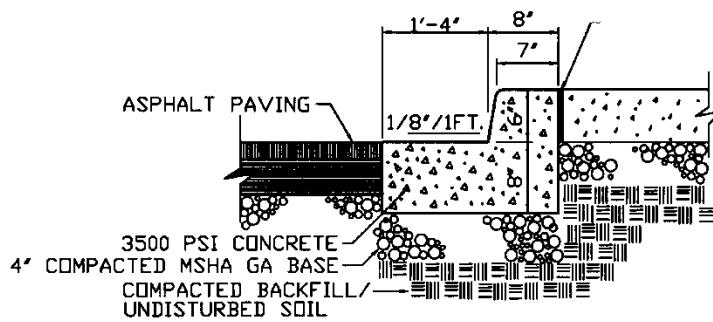

6" & 8" CONCRETE CURB AND GUTTER
NTS

Site Standard Detail #2c

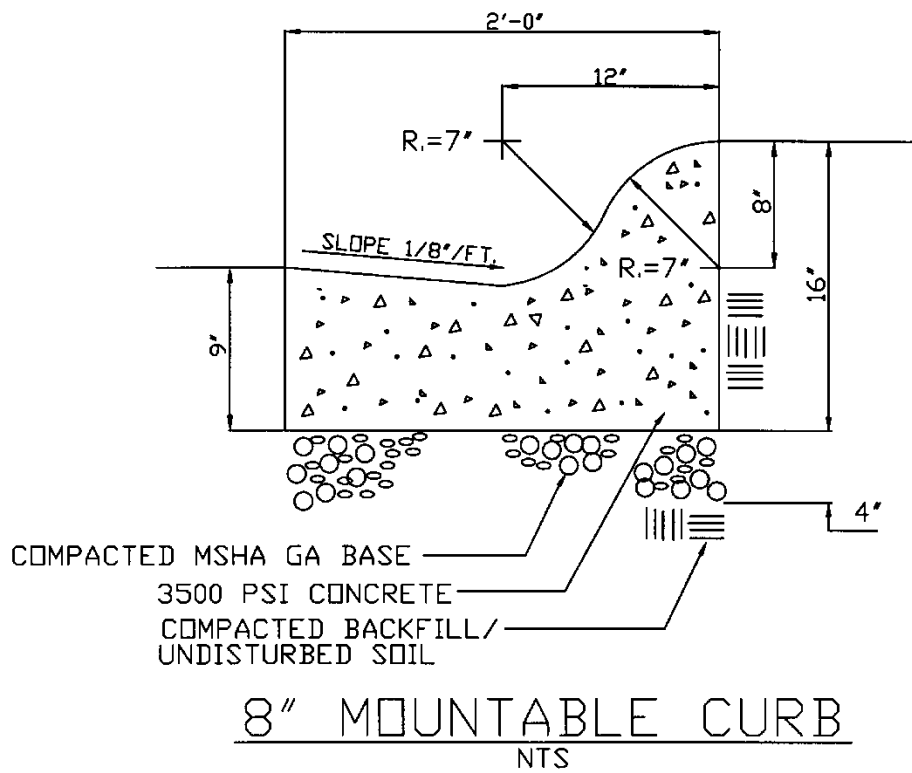

Site Standard Detail #3

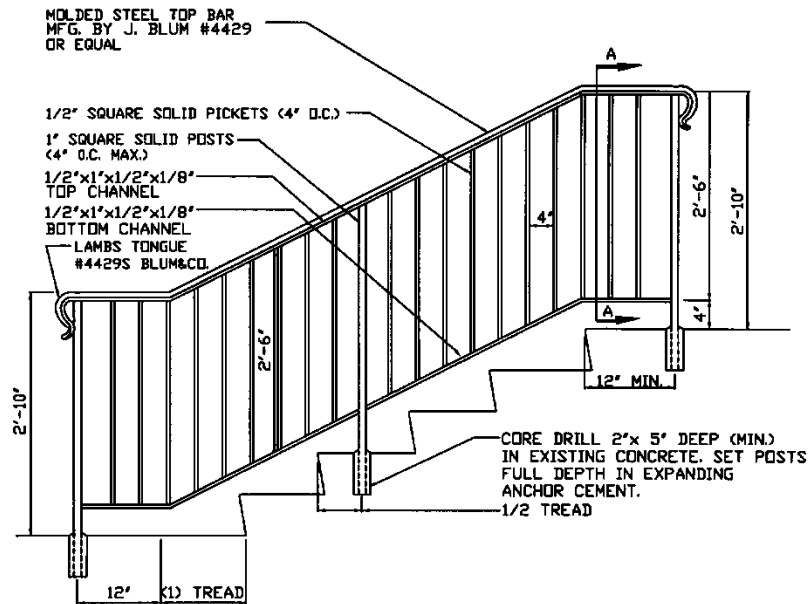

NOTE:

1. PROVIDE HORIZONTAL RAILINGS AT LANDING
2. SLOPE ANCHOR CEMENT AWAY FROM POST AND CONTAIN CLEANLY WITHIN 2" HOLE
3. ALLOW 1" CLEARANCE BETWEEN LAMBS TONGUE AND END POST
4. ALTERNATIVE RAILINGS WILL BE CONSIDERED.

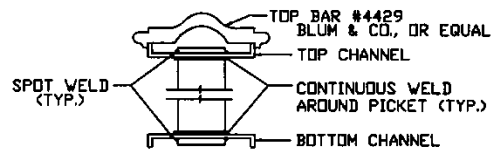

SECTION A-A
NTS

HANDRAIL
NTS

Site Standard Detail #4a

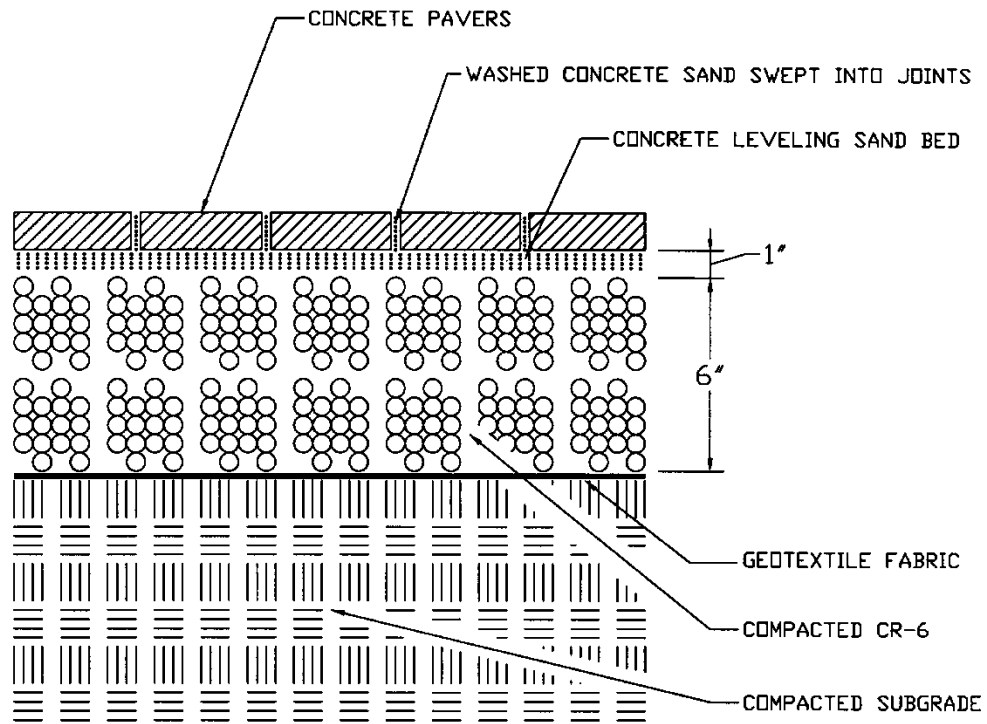

INTERLOCKING CONCRETE PAVERS
NTS

NOTE: CONCRETE PAVER TO BE COMPACTED
WITH VIBRATORY TAMPER

Site Standard Detail #4b

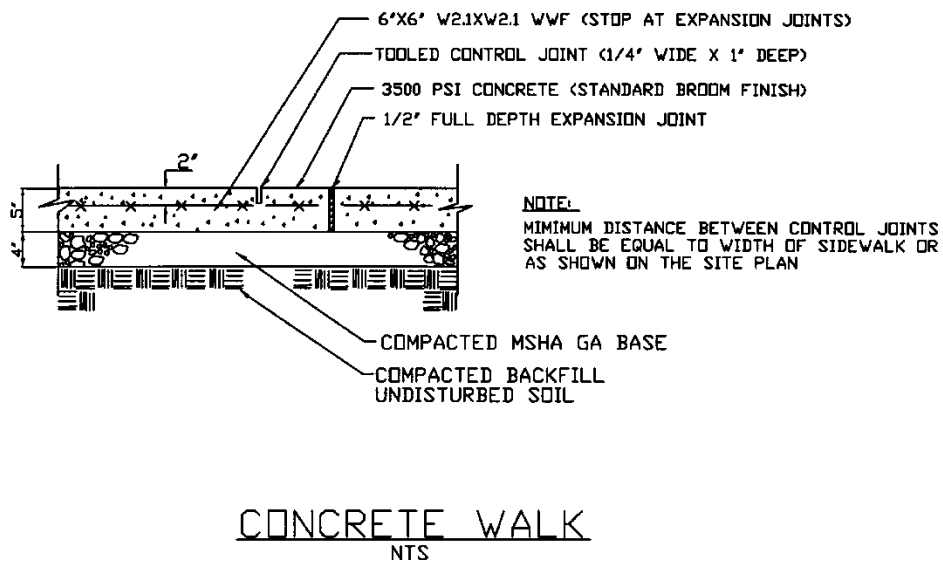

Site Standard Detail #4c

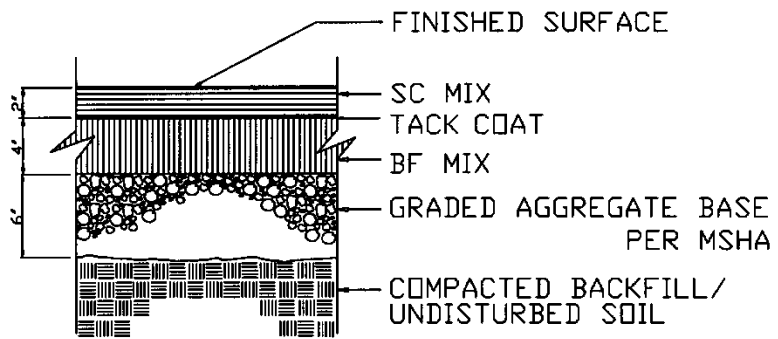

BITUMINOUS ASPHALT PAVING

NTS

NOTE: PROVIDE THIS SECTION ONLY IF ENGINEERED DESIGN IS NOT FEASIBLE, AND ONLY WITH APPROVAL FROM FACILITIES MANAGEMENT

Site Standard Detail #4d

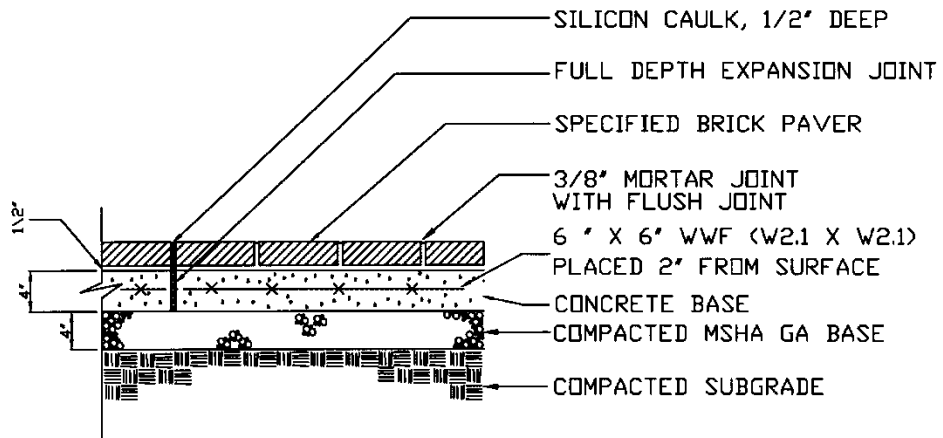

SECTION

BRICK ON CONCRETE
NTS

NOTE: FOR USE IN NON-VEHICULAR AREAS. SEE CONCRETE PAVER DETAIL FOR TYPICAL VEHICULAR PAVER APPLICATION

Site Standard Detail #5a

NOTE:

1. DO NOT INSTALL MULCH WITHIN 6" OF TREE TRUNK
2. INSTALL TOP OF ROOT BALL AT FINISHED GRADE

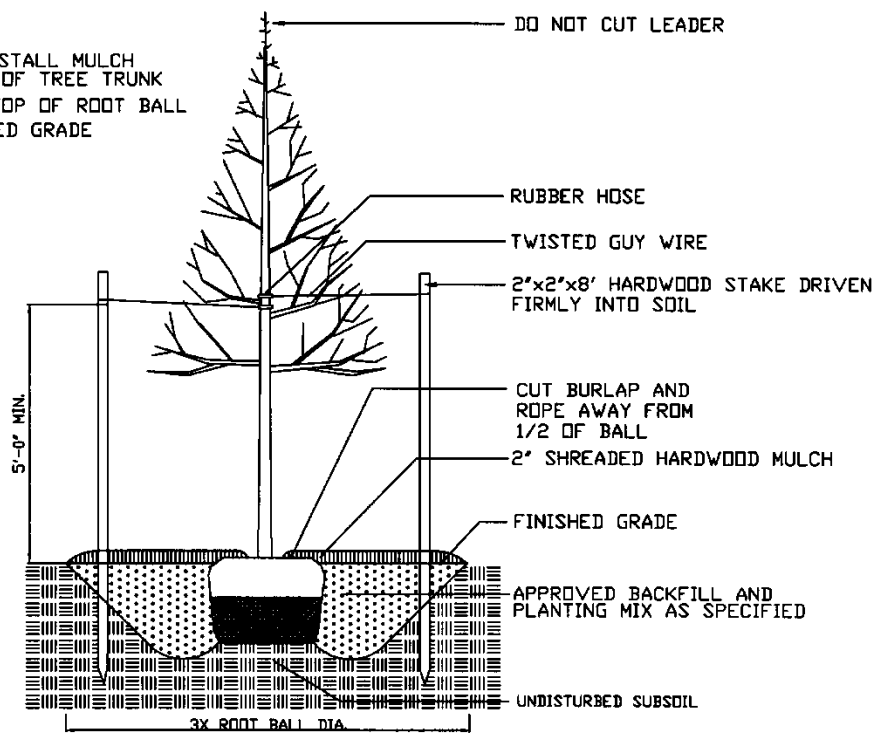

TREE PLANTING DETAIL
NTS

Site Standard Detail #5b

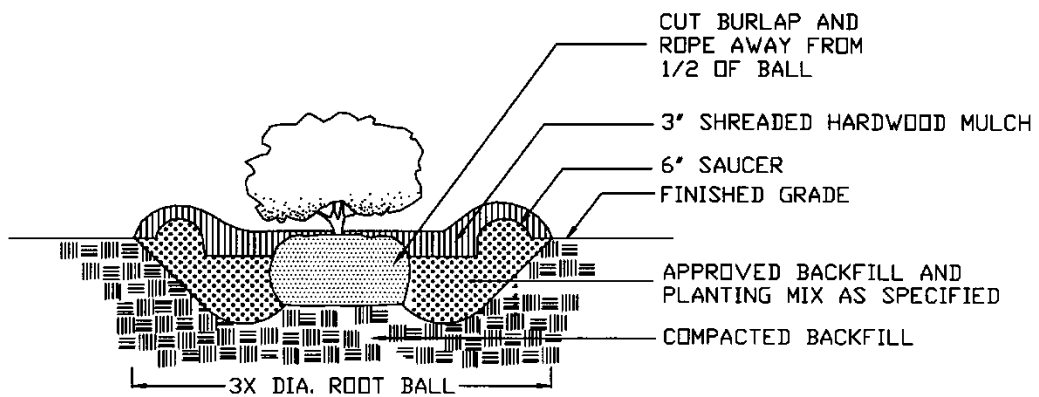

NOTE:
PLANT TOP OF ROOT BALL 2" ABOVE GRADE

CUT CONTAINER GROWN ROOTBALL AS SHOWN PRIOR TO PLANTING

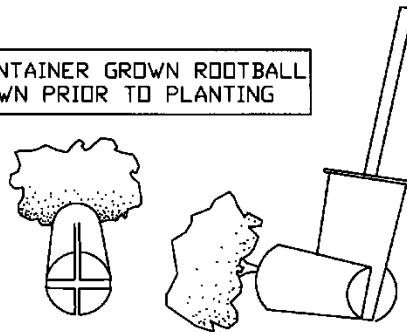

SHRUB PLANTING DETAIL
NTS

- Site Standard Detail #6a

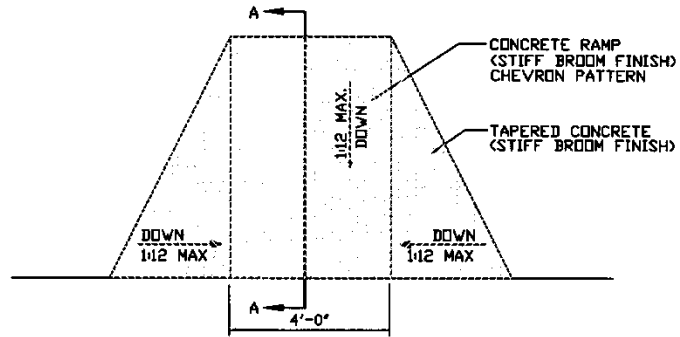

NOTE

- 1. SEE SECTION A-A
- 2. REFER TO ADA STANDARDS FOR SPECIFIC ADJUNCT SITE REQUIREMENTS

PLAN VIEW

CURB RAMP
NTS

Site Standard Detail #6b

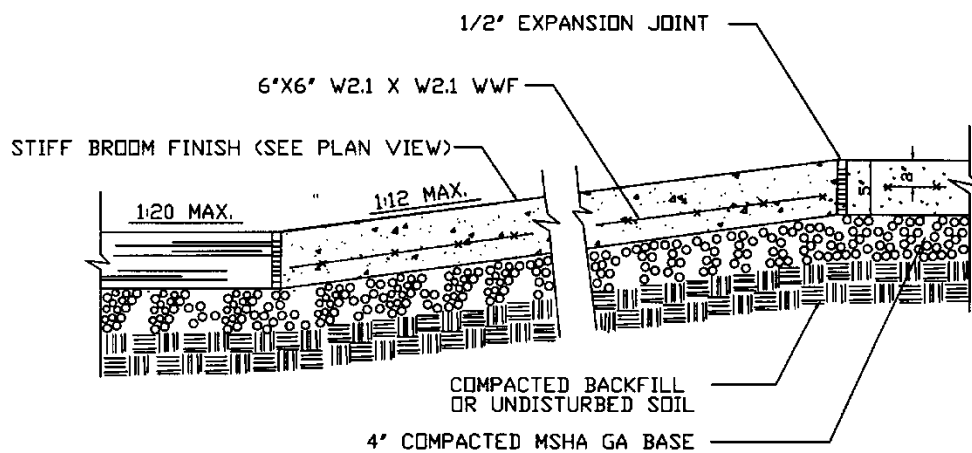

NOTE
3500 PSI CONCRETE (STIFF BROOM FINISH)

SECTION 'A-A'
NTS

PWD RAMP
NTS

Site Standard Detail #7

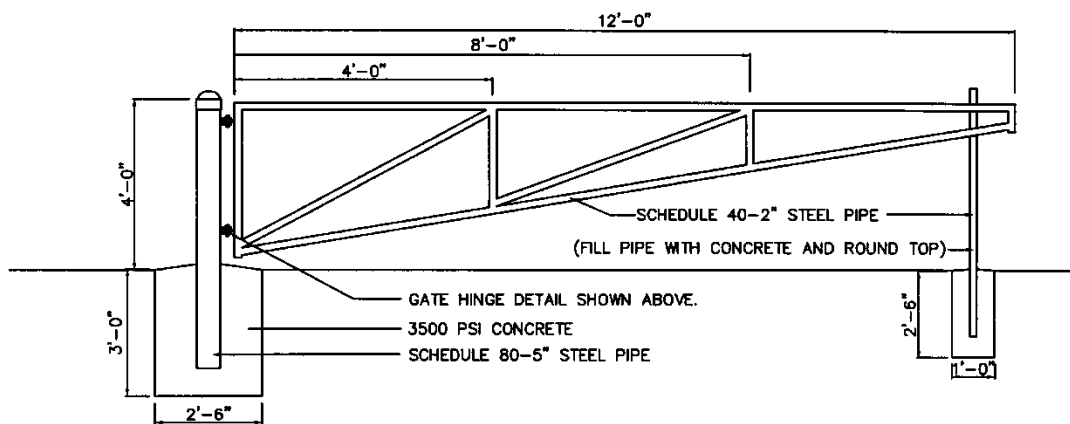

NOTE

1. WELDED JOINTS TO BE CONTINUOUS WELD.
2. APPLY ONE COAT PRIMER AND TWO COATS ENAMEL PAINT, COLOR PER OWNER
3. ATTATCH SIGN TO GATE USING GALVANIZED BOLTS.

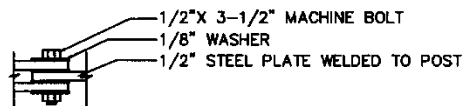

HINGE DETAIL
NTS

SECURITY GATE
NTS

Site Standard Detail #8a

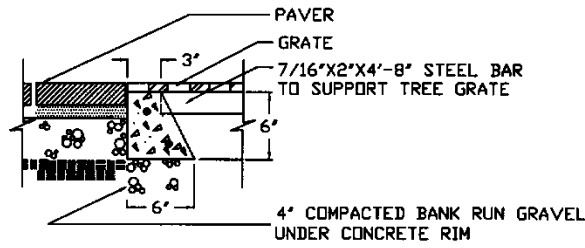

SECTION 'A-A'

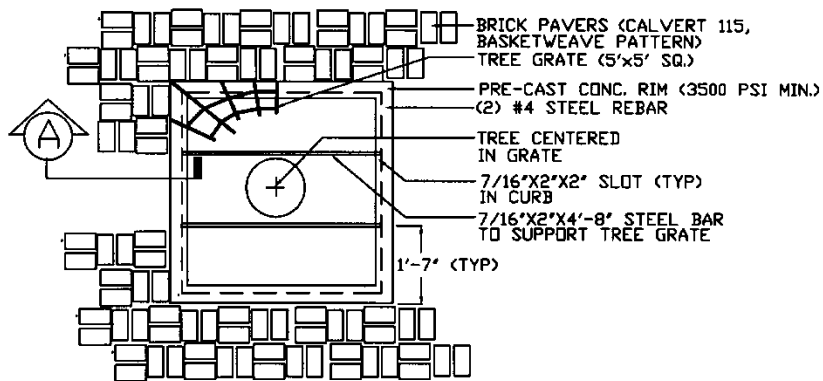

PLAN VIEW

TREE GRATE

NTS

Site Standard Detail #8b

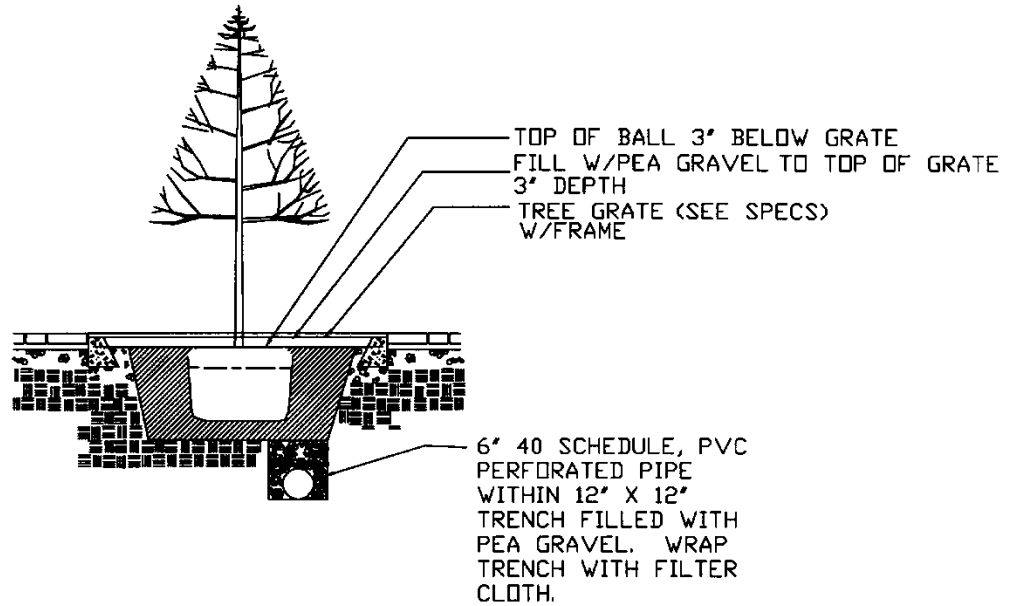

TREE GRATE

NTS